

PITELUMEC

THE PRING-E 300 RING BIT CASING SYSTEM

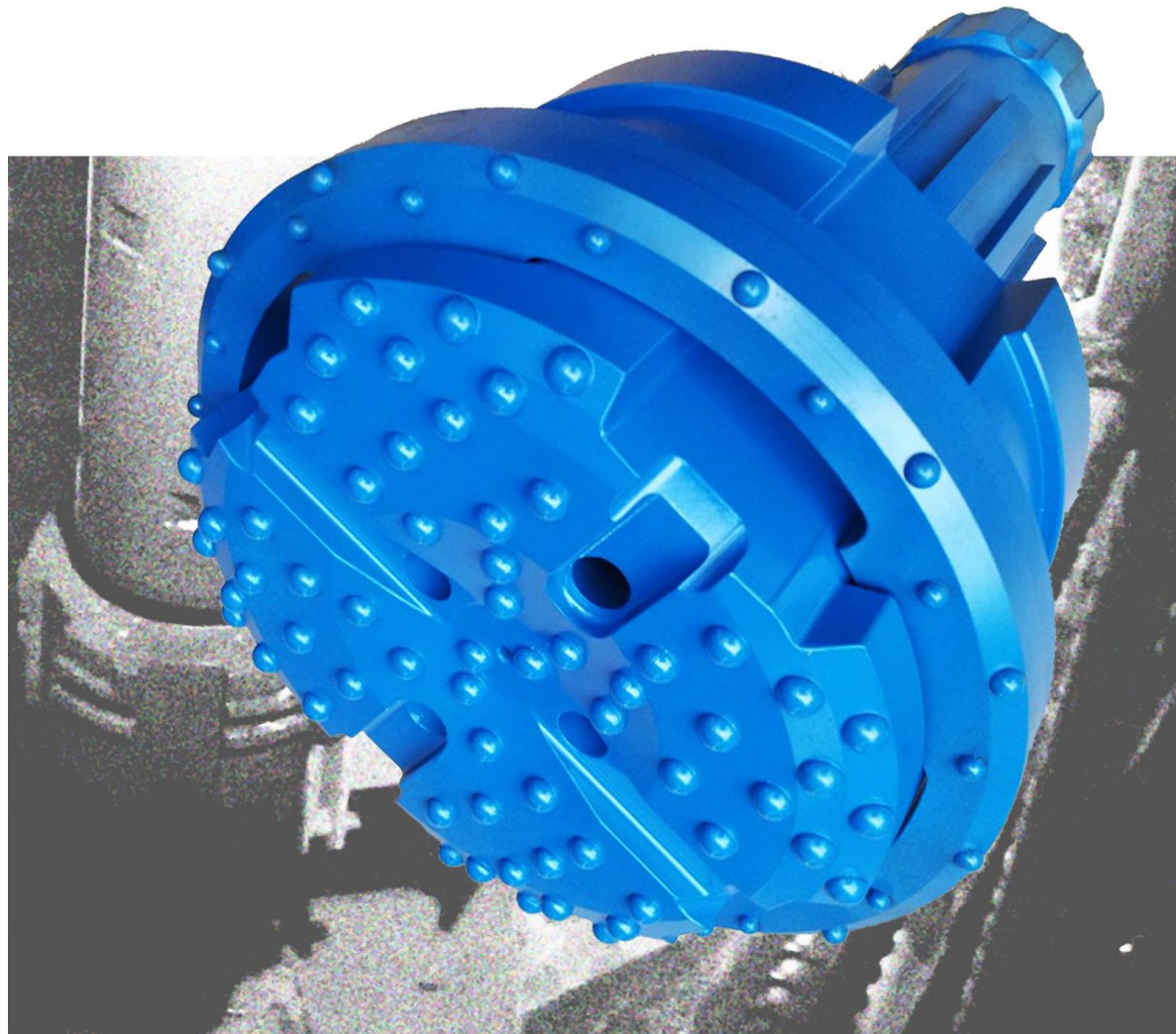

CASING SIZE 355MM OD X 323MM ID DRILLING DIA. 380MM

PNEUMEC PRING-E 300 CASING SYSTEM

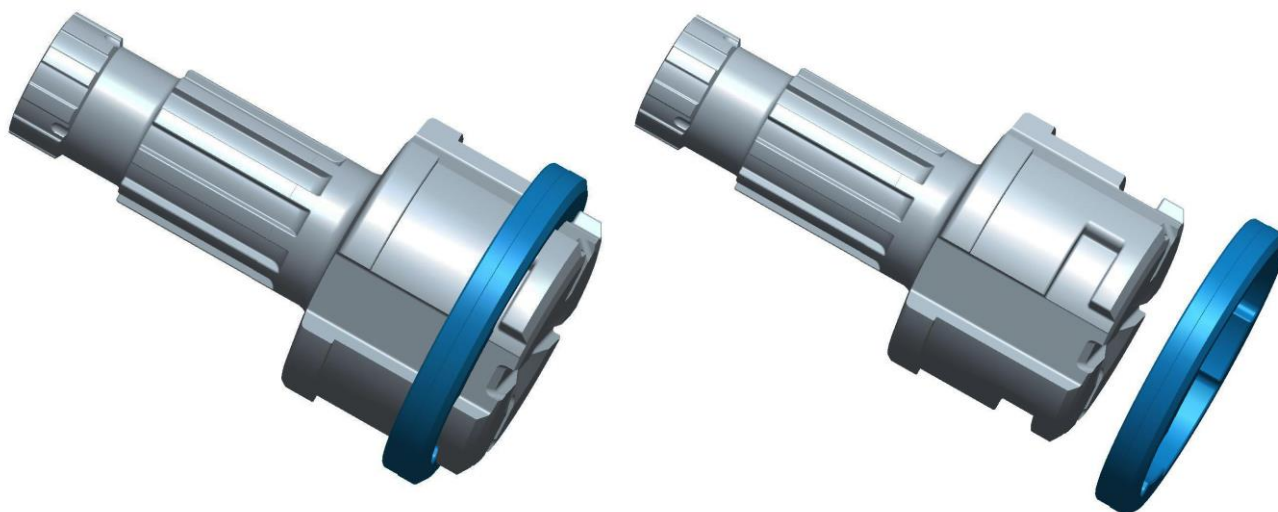

PRING-E 300 PARTS LIST

1.	DRIVER BIT N125 SHANK	UGD300125RE
2.	RING	URB300RE
3.	COMPLETE SYSTEM	UCS300125RE

PRING-E 300 SPECIFICATIONS

UPPER BODY DIAMETER	320MM	RING ID	270MM
RING OD	380MM	CASING SIZE	355MM OD X 323MM ID
SYSTEM LENGTH	780MM	SYSTEM WEIGHT	255KG

PRING-E 300 CASING SHOES

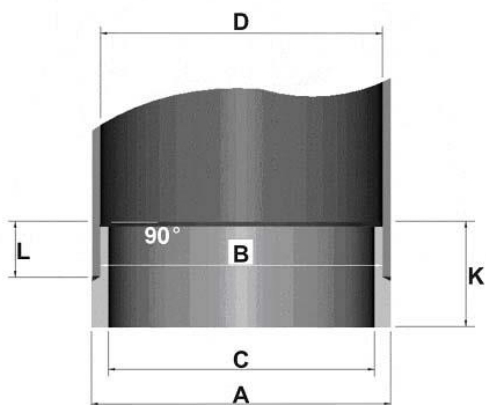

DIA. A	355MM
DIA. B	320MM
DIA. C	303MM
DIA. D	323MM
L	40MM
K	90MM



PNEUMEC COMPANY LIMITED

1st Floor, Tin On Sing Comm. Bldg., 41-43 Graham St. Central, H.K.

Tel : (852) 2180 9922

Website : www.pneumec.com

Fax : (852) 2180 9982

email : info@pneumec.com